

Installation and Operating Instructions

Lumistar Luminaire USL 06

• Important, please note:

Sight glass luminaires are purpose-designed and intended solely for mounting on top or on the side of sight glass flange fittings. Under no circumstances should a sight glass luminaire be used to replace the mating flange or the entire sight glass flange fitting, nor should it be used to cover an opening in a process vessel.

• Operating conditions – general:

- Independent of vacuum/pressure in the vessel; max. admissible ambient temperature for halogen lamp version at the cable entry gland is 80°C.

In places where ambient temperatures exceed 40°C, heat resistant cable such as Sinothem 110 H05GG-F 3G 1.5 mm² should be used. The maximum ambient temperature for the LED version is 40°C.

- Never use lamps with a higher wattage than specified.
 Danger: the luminaire housing will be subjected to too much heat!

• Electrical data – general:

- The voltage, power and IP rates are shown on the type plate
- The version with integrated transformer is PTC protected, no fuse replacement necessary
- Voltage type: AC/DC, depending on the luminaire set-up
- Caution: Luminaires with an integrated transformer or high-voltage timer must be operated with AC voltage
- Caution: Overvoltage will cause premature lamp failure!
- 10% admissible voltage tolerance

• Electrical connection:

- The connecting cable selected should comply with the operating conditions
- The cable diameter must match the cable gland (M20x1.5)
- Loosen and unscrew the lens ring (3) using the claw spanner
- Unscrew the cable entry gland (1)
- Insert the cable through the cable entry gland (1) and connect the wires to the terminals in the luminaire body (2)
- Tighten the cable entry gland (1). Refit the O-ring seal in the groove of the luminaire body (2)
- Screw the lens ring (3) in place again until the seal has been established



Application as combined light/sight port, fitted to a circular sight glass assembly to DIN 28120; fastened with hinged bracket

• Lamp change/LED change:

- Disconnect the luminaire from the power supply, allowing it to cool down if necessary
- Unscrew the lens ring (3) using only the special claw spanner
- Pull out (2-pin) the defective lamp
- GZ-socket: turn the illuminant easily and remove it.
- Please use only original spare parts!
- Holding the new lamp with a cloth, insert it carefully into the 2-pin holder and push it into place, or screw it in
- Check that the lamp is properly seated!
- Screw in the lens ring (3) again until it is tight (pressure on the O-ring)
- Reconnect power supply

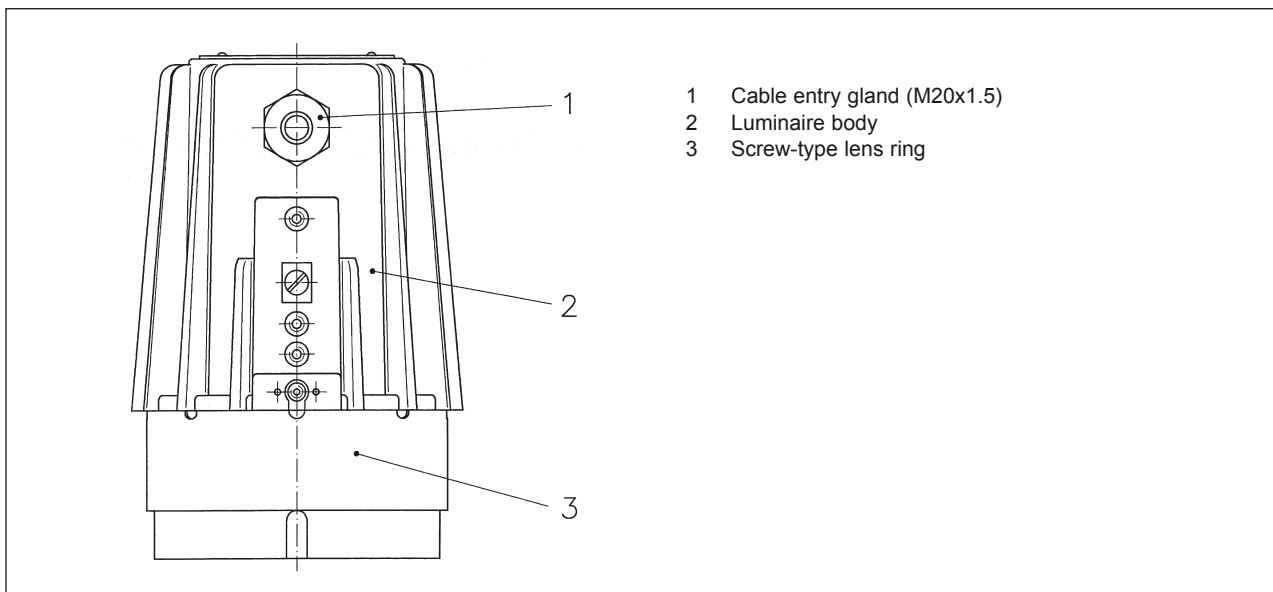

- 1 Cable entry gland (M20x1.5)
- 2 Luminaire body
- 3 Screw-type lens ring

• **Mechanical installation:**

- Before starting installation work, it is essential to read the information leaflet "Important guidelines when using sight glass fittings".
- Caution: Do not look into light – danger of impaired eye-sight!

With circular sight glass fittings and on flow indicators, the luminaire is attached to the cover flange using the hinged bracket. For screw-type sight glass fittings, the luminaire is mounted on the slotted cover nut, or alternatively fixed in place using a hinged bracket or flanged adapter.

• **The Lumistar luminaire USL 06 is suitable for the following nominal sizes with the appropriate mounting in each case:**

Type of fitting	from DN	Hinged bracket	Flanged adapter
Circular sight glass fitting			
DIN 28120	50	+	-
DIN 28121	50	+	-
Flow indicator	50	+	-
Screw-type	65	-	+
sight glass fitting	80	+	+
similar to DIN 11851	100	+	+
	125	+	-

• **Mounting with hinged bracket:**

The hinged bracket is intended for attaching the luminaire to the cover flange of a circular sight glass fitting (or a sight glass in a flow indicator), or to the slotted cover nut on a screw-type sight glass fitting to DIN 11851. The hinged bracket is secured to the port using the M8 screw supplied which is held in a blind hole to be drilled and tapped in the circumference. Alternatively, the hinged bracket can be welded in place.

• **Mounting with flange adapter collar:**

The flanged adapter is mounted on the slotted cover nut (DIN 11851) using a screwed or welded connection. Slide the luminaire into the adapter collar. Tighten the retaining screws on the side.

• **Please note:** Fastening parts and claw spanner should be ordered separately if required.

• **Replacement parts:**

	Part no.
Screwed lens ring (light exit) with reflector	1774.037.00
Screwed lens ring (light exit) without reflector	1774.036.00
O-ring seal (Viton) for screwed lens ring	0862.036.00

Lamp socket, G4 (2-pin)	1202.011.00
Lamp socket, GY6.35 (2-pin)	1202.012.00
Lamp socket, GZ10	1202.024.00

Halogen lamps:	
12 V/20 W – GY6.35	3232.240.00
24 V/20 W – G4	3232.206.00
(Reflector integrated in lens ring)	
224 V/50 W – GY6.35	3232.242.00
120 V/50 W – GY6.35	3232.265.00
230 V/50 W – GZ10	3232.261.00
24 V/100 W – GY6.35	3232.244.00

LED illuminants:	
24 V/4 W – GU5.3	3233.005.00
230 V/7 or 8 W – GZ10	3233.010.00
230 V/5 W – GZ10	3233.029.00

• **Accessories:**

Claw spanner	6816.001.00
--------------	-------------

• **Servicing:**

- Keep the luminaire clean
- After opening the luminaire, lightly lubricate the thread of the lens ring again (e. g. with AEMA-SOL 6 B, made by A. E. Matthes)
- Take note of the average life of the lamp
- Use only original replacement parts