

# SPARTAN



## Floodlight Range Installation Guide

Zone 1 variant CML13ATEX3007 or IEC Ex CML14.0001 or CML 21UKEX3099

Zone 2 variant CML17ATEX4231 or IEC Ex CML 17.0135 or CML 21UKEX4106

This installation guide provides instructions for installing the Infra-Red and White-Light SPARTAN series of explosion protected floodlights.

Text in **Bold** is specific for emergency variants

### Overview

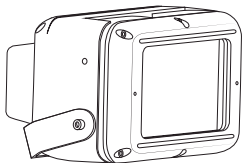

- 1 Safety Instructions
- 2 Installation
- 3 Maintenance
- 4 Technical Specification
- 5 Trouble Shooting

### Important information

The SPARTAN series of explosion protected floodlights are specialist devices, certified for use in specific operating environments.

The units must be installed in accordance with these instructions, must be correctly certified for the specific operating environment and must be installed by suitably qualified personnel.

**Emergency floodlights will require the fuse to be reconnected upon installation and the floodlight subjected to three 24 hour charge/discharge cycles to bring the battery up to peak capacity.**

If you have any queries about the installation or the certification of the unit – please contact Raytec for immediate assistance and advice.

# 1. Safety instructions

1. Read this leaflet carefully before commencing to install the SPARTAN unit and retain it for future use. Installation can only be carried out by suitably qualified personnel.
2. Check the certification and "T" rating to ensure that the mains supply and the ambient temperature present is suitable for the unit being installed.
3. If the SPARTAN unit is to be installed in areas of high vibration, please consult with Raytec.
4. Externally the SPARTAN unit housing is constructed from marine grade aluminium, and toughened glass, stainless steel brackets/fasteners and silicone gaskets, internally there are many non metallic components. The end user must ensure that these materials are suitable for the environment the SPARTAN unit will be installed in; Zone 1 and Zone 2 Hazardous areas.
5. SPARTAN units are designed to withstand marine environments and are tested in accordance with IEC60068-2-52. However if the SPARTAN unit is to be installed in a very high corrosive environment such as **coastal** and **offshore** the following good practice should be followed:

**During installing** ensure there are no scratches, chips or defects in external paint surface that would allow ingress of water to bare aluminium. If so touch up with suitable paint

**During installation** apply an anti corrosive jointing compound to screw threads such as PSU cover and external earth points.

**During installation** ensure exterior surface of the product is not in direct contact with a dissimilar metal such as galvanised steel. If so fit a nylon barrier to prevent galvanic corrosion.

**During maintenance** regularly wash down external surface of fitting with clean, fresh water to remove any deposits of mineral salts on the exterior surface.

6. Check certification nameplate on side of floodlight to ascertain type of threaded cable entry on the luminaire. Select suitably certified ATEX/IEC Ex /UKEX cable glands and stopper plugs, these must be parallel thread, have a minimum of 5 full thread engagement and be of a medium/fine tolerance to ISO965-1 and ISO965-3. The cable entry devices selected must maintain the IP rating of the luminaire
7. The incoming mains cable should not exceed a temperature rise of 20°C above the ambient conditions; select suitable cable.
8. When the unit is installed correctly and in accordance with these installation instructions it will not harm humans or animals.
9. Before installing emergency luminaires please check the last charge date of the battery. This is shown on the external product packaging and also on the battery label, alternatively consult date shown on the declaration at the back of this leaflet. If the last charge date was in excess of 3 months (if stored at 5°C to 25°C) or 1 month (if stored outside this range) from date of installation, please consult Raytec document 0010-D-00001 Battery Handling Guide

## 2. Installation

### Mounting SPARTAN Unit

1. To meet the requirements of certification a MINIMUM of 2 fixing points must be used, the fixing points must be suitable for the conditions of use. Raytec recommend using M8 Marine Grade A4 Stainless Steel fixings (not supplied)

#### Spartan 24 (Emergency Variant Shown)

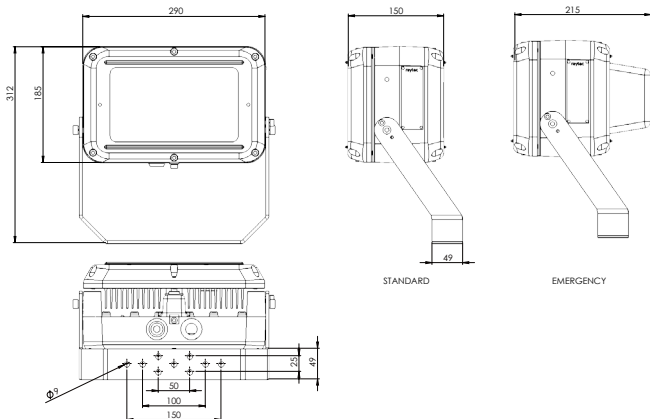

## Spartan 48

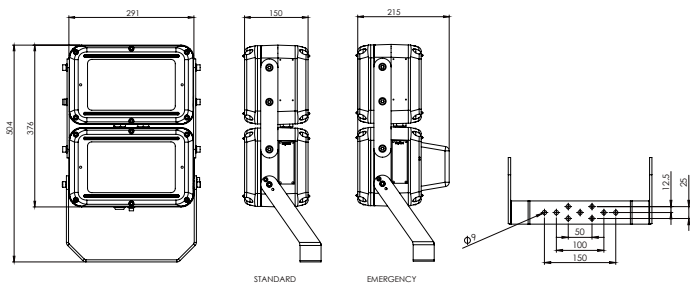

2. The SPARTAN floodlight and the mounting bracket is supplied together as a unit. The bolts in the side of the housing shall be removed and used to secure the bracket to the SPARTAN housing, the bracket can be attached in the top or bottom position depending on the mounting application, where possible the cable glands should be kept to the bottom of the floodlight. It is very important that the red fibre washers are fitted between the SPARTAN housing and the mounting bracket. The unit must be aligned first before securing the bracket, and bolts tightened to 15Nm. On SPARTAN 24 and 48 units a locking screw is provided to lock the luminaire at various angles, which should be tightened to 4Nm. The unit can be mounted horizontally or vertically allowing the unit to point up/down or left/right.

## Typical wiring diagram – standard luminaires

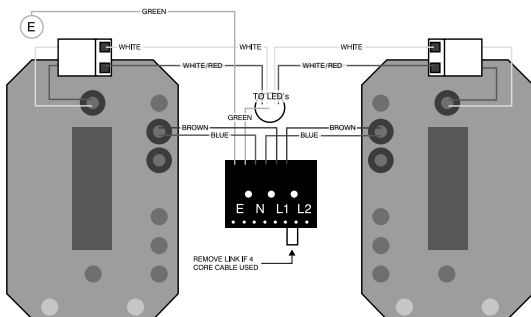

## Typical wiring diagram – emergency luminaires

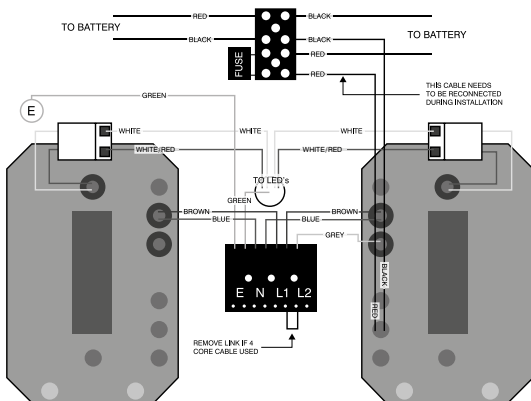

3. Open the rear compartment to access terminal block. Wire the Mains cable into the terminal block. Provision has been made for this and identified as the E (Earth), L1 (switched live) and L2 (permanent live) and N (Neutral) terminals. There are two pairs of contacts for each of these to facilitate a mains cable that can be looped in and out of the unit. The L2 terminals on a standard unit is not electrically connected but allows them to be used on the same circuits as **emergency floodlights**.
4. Installer should earth the unit separately – an internal and external earth point are provided as standard.
5. Connect wires to mains supply.
6. If the unit is opened for any reason, disconnect mains – **On emergency luminaires there may be more than one mains supply**.
7. All SPARTAN floodlights have terminal blocks suitable for looping 4mm<sup>2</sup> cable, only one cable should be connected to each terminal block connection.
8. **Emergency SPARTAN floodlights may have a single green LED fitted adjacent to the incoming cable glands, when illuminated the green LED indicates that the emergency system is healthy.**
9. **The battery fuse located in the power supply lid on emergency variants is disconnected after final manufacturing testing. When installing the floodlight the battery fuse will need to be reconnected and the unit charged for 24 hours and then discharged (repeated 3 times) to bring the battery up to peak capacity.**
10. **If a 4 core cable is used on emergency luminaires – L1, L2, N and E the link cable at the front of the terminal block between L1 and L2 should be removed.**
11. **During emergency operation the light output and duration will be determined by the variant purchased.**
12. Once wiring is complete replace rear cover. Ensure gasket is located neatly in channel and no wires are trapped between cover and body. Tighten cover screws to 3Nm.
13. If carrying out Insulation Resistance tests the normal method of insulation testing is to connect Live and Neutral together and test between this point and Earth to prevent the risk of damage to the electronic control gear.

### 3. Maintenance

1. It is essential that all SPARTAN units are maintained in accordance with the requirements of the EN60079-17 standard: (Electrical apparatus for explosive gas atmospheres – other than mines).
2. **IMPORTANT.** No modifications are permitted to the unit, all spare parts must be purchased from the manufacturer, unauthorized modifications or spare parts will invalidate certification and make the equipment dangerous.
3. Isolate the SPARTAN unit from the mains supply and allow to cool before carrying out any maintenance work.
4. The unit has 2 independent power supplies, in the event that a power supply needs to be replaced the cables to the LED and mains terminal block will need to be disconnected, the four M6 bolts released the power supply can then be removed. Fitting a new power supply is a reversal of the above procedure.
5. Disposal of packaging, SPARTAN unit and old LED assemblies should be carried out in accordance with national regulations.

## 4. Technical Specification

	Spartan 24	Spartan 48
<b>Input Voltage</b>	110-254V AC or 18-48V AC/18-69V DC or 12V DC	
<b>Consumption</b>	68W max	136W max
<b>Consumption (Emergency variant)</b>	71W max	139W max
<b>Power Factor</b>	>0.95	
<b>Mains Frequency</b>	50/60Hz	
<b>Inrush Current (Ipeak @ 50%)</b>	40A $\Delta t < 300\mu s$	
<b>Total Harmonic Distortion (230Vac full load)</b>	<10%	
<b>IP Rating</b>	IP66/67	
<b>Weight Environment</b>	Standard - 8kg (17.6lbs) Emergency - 10Kg (22lbs)	Standard - 16kg (35.2lbs) Emergency - 20Kg (44lbs)
<b>Weight Environment (Emergency variant)</b>	11.5kg (25.3lbs)	21kg (46.3lbs)
<b>Dimensions Dimensions</b>	See previous pages for line diagrams	
<b>ATEX and IECEx and UKEX Rating</b>	See below	

### Protection/Certification

CML13ATEX3007 or IEC Ex CML14.0001 or CML 21UKEX3099

II 2 GD Ex eb mb IIC T4/T5 Gb

Ta -52°C to +55°C (standard variants)

II 2 GD Ex eb mb IIC T6 Gb

Ta -52°C to +48°C

II 2 GD Ex eb mb IIC T4 Gb

Ta -20°C to +55°C (emergency variants)

Ex tb IIIC T82°C Db

IP66 & IP67 Ta = -52°C to +55°C

110V-254 AC or 18-48V AC/18-69V DC

CML17ATEX4231 or IECEx CML 17.0135 or CML 21UKEX4106

II 3 GD Ex ec mc IIC T4 Gc

Ta -50°C to +55°C (standard variants)

II 3 GD Ex ec mc IIC T4 Gc

Ta -20°C to +55°C (emergency variants)

Ex tc IIIC T82°C Dc

IP66 & IP67 Ta = -50°C to +55°C

110V-254V AC or 18-48V AC/18-69V DC



## 5. Trouble Shooting

1. Ensure the two LED boards are correctly wired to terminal block.  
White to White : White/Red to White/Red
2. Ensure Mains input is correctly connected.
3. Ensure Mains Input is turned on at the source
4. On emergency variants check fuse to ensure it has not blown
5. If LED panel fails to light is it possible to identify if problem is with LED panel or power supply by swapping LED cables to opposite power supply to help identify problem.

Max number of fittings allowed per MCB  
(Based on 230V)

MCB Type	Rating	FL24	FL48
B	10A	5	2
B	16A	8	4
B	20A	12	8
B	25A	17	8
C	10A	12	6
C	16A	17	8
C	20A	24	12
C	25A	29	14

**Declaration Of Conformity**  
**With The Atex Directive 2014/34/EU**  
**& UK Directive SI 2016 No. 1107 (as amended)**



Raytec Ltd. declares under our sole responsibility that the product(s) listed below conform with the relevant provisions of directive 2014/34/EU of 20th April 2016 and UK Directive SI 2016 No. 1107 (as amended)

Manufacturer	Raytec Ltd Unit 15, Wansbeck Business Park Rotary Parkway Ashington Northumberland, NE63 8QW United Kingdom
Description of Equipment	Spartan range of floodlights – standard and emergency
Certification Body	CML New Port Road Ellesmere Port, CH65 4LZ
Certificate	Zone 1 - CML13ATEX3007, IEC Ex CML14.0001 & CML21UKEX3099 Zone 2 - CML17ATEX4231, IEC Ex CML17.0135 & CML21UKEX4106 ATEX Quality Assurance Notification CSA BV (2813) UKCA Quality Assurance Notification CSA UK (0518)
Equipment Marking	II 2 GD Ex eb mb IIC T4/T5 Gb Ta -52°C to +55°C (standard variants) II 2 GD Ex eb mb IIC T6 Gb Ta -52°C to +48°C II 2 GD Ex eb mb IIC T4 Gb Ta -20°C to +55°C (emergency variants) Ex tb IIIC T82°C Db IP66 & IP67 Ta = -52°C to +55°C 110V-254V AC or 18-48V AC/18-69V DC  II 3 GD Ex ec mc IIC T4 Gc Ta -50°C to +55°C (standard variants) II 3 GD Ex ec mc IIC T4 Gc Ta -20°C to +55°C (emergency variants) Ex tc IIIC T82°C Dc IP66 & IP67 Ta = -50°C to +55°C 110V-254V AC or 18-48V AC/18-69V DC

Compliance with the Essential Health and Safety Requirements has been assessed by reference to the following harmonised/designated standards -

EN 60079-0 : 2018      EN 60079-7 : 2015 + A1 : 2018

EN 60079-18 : 2015 + A1 : 2017      EN 60079-31 : 2014

And also 2014/35/EU - Low Voltage Directive, 2014/30/EU - EMC Directive

**Signed**



**Name**  
**Position**

Barry Thompson  
Director

**Dated**

**Serial number**



---

**Raytec Global (excluding Americas)**

Tel: +44 (0) 1670 520055  
sales@rayteclcd.com

Raytec Ltd.  
Unit 15 Wansbeck Business Park, Rotary Parkway  
Ashington, Northumberland, NE63 8QW, United Kingdom

[rayteclcd.com](http://rayteclcd.com)

**Raytec Americas**

Tel: +1 613 270 9990  
sales@rayteclcd.com

Raytec Systems Inc.  
800-300 Terry Fox Drive, Ottawa, Ontario  
2K 0E3, Canada