

Lumistar Luminaire ME-LED

Sizes: 65, 80, 100, 125

- **For use with screwed sight glass fittings**
For the combination of sight and light glass ports, suitable for round screwed sight glass fittings according to DIN 11851 or similar, DN 65 to DN 125
- **Application:**
For the illumination of pipelines, laboratory mixers as well as the interior of vessels, tanks, agitators and other normally closed containers in non-explosive operating areas. Suitable for food processing plants.
- **Protection:**
When correctly fitted, dust-tight and splash water protected, IP 65 to EN 60 529/DIN VDE 0470 Part 1
- **Maximum permissible ambient temperature at the cable entry:**
40°C
- **Attention:** Do not look into the light – danger of impaired eyesight!
- **Electrical data:**
Operating voltage/power:
ME 65-LED and ME 80-LED: 12-24 V DC – 1.5 W
ME 100-LED and ME 125-LED: 24 V AC/DC – 2.0 W
Colour temperature: 5000 K
Luminous flux: 1.5 W = 104 lm; 2.0 W = 170 lm
- **Beam angle:** 26° or 33°
- **Transformers or electronic power supplies** can be supplied on request.
- **Built-in switch:** The Lumistar luminaires ME-LED can be supplied with or without built-in push button switch.
- **Attention:** The luminaire should not be connected to the power supply until the mechanical installation is complete.
- **Electrical connection:**
The Lumistar luminaire ME-LED is factory fitted with a 3 m temperature-resistant connecting cable (Lapptherm 105, up to 90°C), which is connected to the luminaire ready for operation. Other cable lengths are available on request. The connecting cable is connected to the voltage source.

The polarity must be observed:

Wire color	12-24 V DC	24 V AC/DC
brown	(+)	(~)
blue	(-)	(~)
green-yellow	(⊥)	(⊥)

- **Mechanical installation:**

- Please pay attention to the slotted cover nut (see table)
- Loosen the slotted cover nut of the screwed sight glass fitting
- Lead the slotted cover nut over the connecting cable and lamp housing
- Ensure the sight glass is correctly positioned in the fitting

CE

3755.563



Lumistar luminaire ME-LED, installed in a screwed sight glass unit similar to DIN 11 851

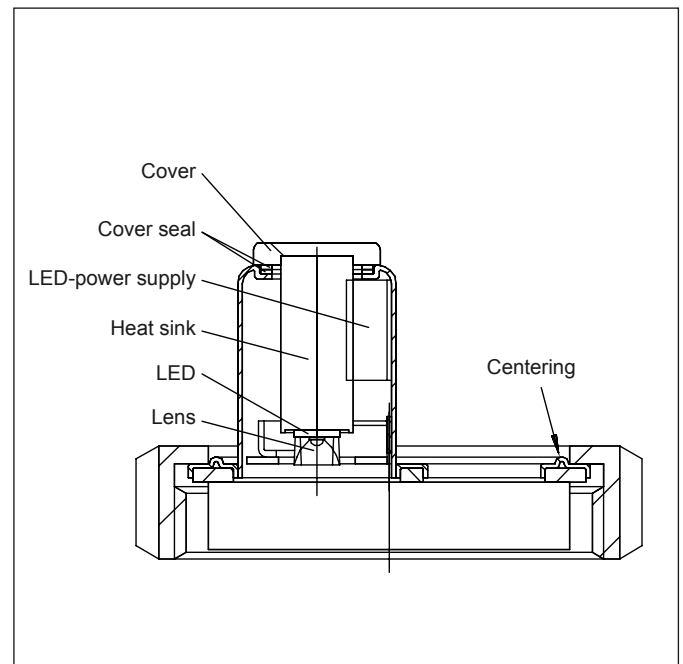

Mechanical construction of Lumistar luminaire ME-LED

- Focus the luminaire, making sure to align the centring feature on the slotted cover nut (see sketch)
- Screw the slotted cover nut tight against the welding adapter with the luminaire fitted

• **Dimensions and connection data for Lumistar luminaires ME-LED:**

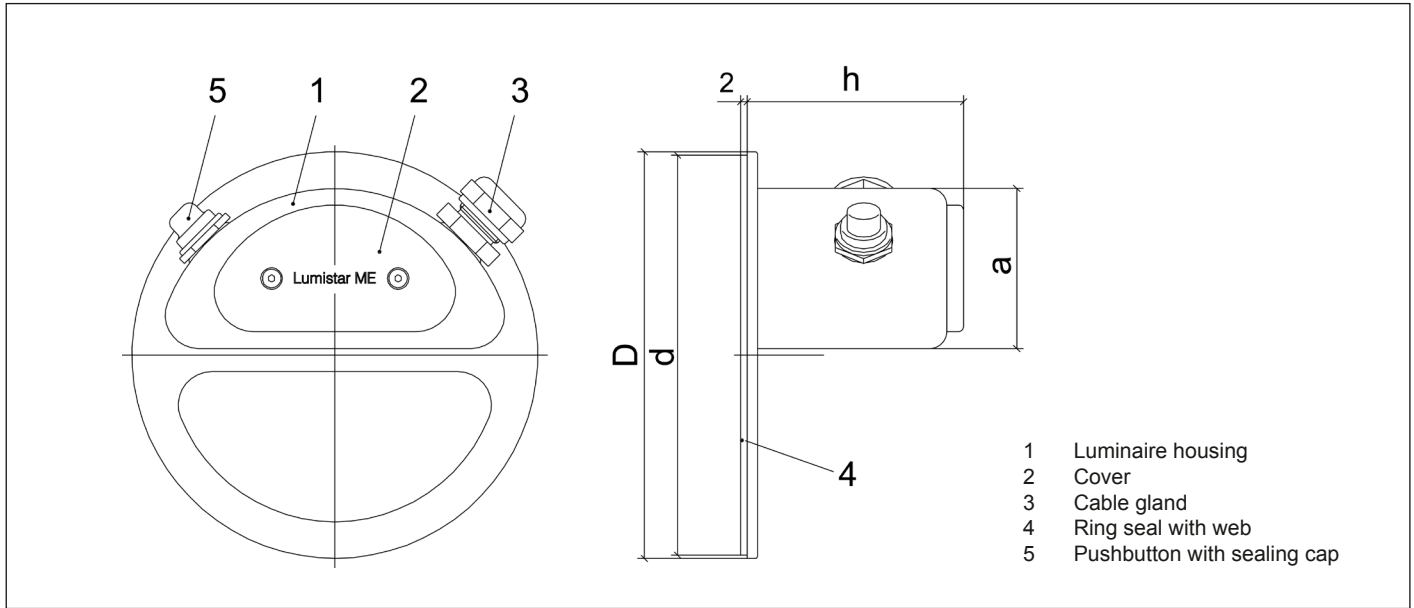

• **Parts, design and construction:**

- The Luminaire is made of stainless steel 1.4301 (suitable for use in food processing, pharmaceutical industries)
- Luminaire cover (2) is fitted with resilient flat seal and screws into the luminaire housing (1)
- A push-button switch with separate sealing cap (5) is a standard feature for short-term operation
- Electrical cable connection through cable gland (3)
- Connection cable: supplied with 3 m cable ready for operation, Lappterm 105, up to 90°C. Other cable lengths are available on request.

Size		1	2	3	4*
Lumistar luminaire ME-LED	Type	ME 65-LED	ME 80-LED	ME 100-LED	ME 125-LED
suitable for screwed sight glass fitting acc. to DIN 11851 or similar	DN	65	80	100	125
Operating voltage	V	12-24 DC	12-24 DC	24 AC/DC	24 AC/DC
Power	W	1.5	1.5	2.0	2.0
Dimensions (mm)	D	89	102	122	152
	d	86	99	119	149
	a	35	35	48	48
	h	50	50	65	65
Nut opening according to DIN 11851	d8	80	94	115	138
Weight approx. (with connecting cable)	kg	0.340	0.360	0.460	0.480
Part no. (with pushbutton)		3544.501.00	3544.521.00	3544.541.00	3544.561.00
Part no. (without pushbutton)		3544.502.00	3544.522.00	3544.542.00	3544.562.00

*Combination: The Lumistar luminaire ME 125-LED can be combined with the Lumiglas sight glass wiper SW I.

- **Order data:** e.g. Lumistar luminaire ME 65-LED, 24 V DC – 1.5 W, with pushbutton, part no. 3544.501.00

• **Important ordering information:**

If the Lumistar luminaire ME-LED is to be mounted on an already fitted screw-type sight glass fitting, a specially adapted slotted cover nut should be ordered at the same time, or an existing one must be mechanically adapted.

If required, please contact your Lumiglas distributor (see also bore diameter ,d 8' according to DIN 11851).