

SALUKA-N-LED, MULTISALUKA-N-LED, SALUKA-N-LED-Em

Technical conditions of the lighting fixture installation

ENG

17.01.2022/ rev.1

FTZÚ 17 ATEX 0027X

⊕ II 3G Ex nR IIC T6 Gc

⊕ II 3D Ex tc IIIC T80°C Dc

IP66, instulation class I

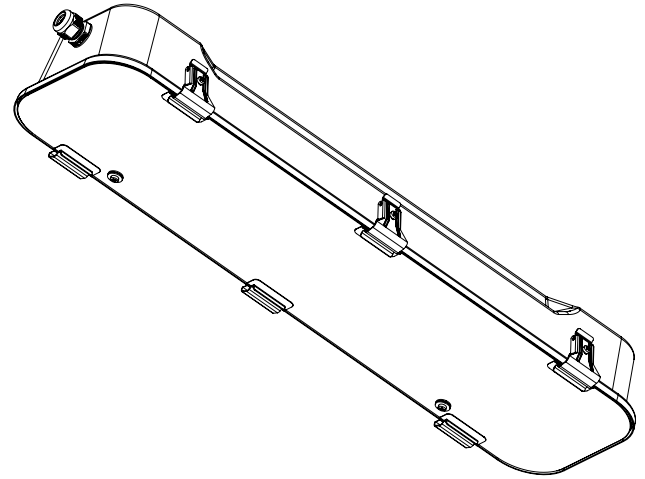

The explosion proof light fitting meet the standards according to the EU instuctions 2014/34/EU. They can be used in areas with danger of explosion according to the following chart:

Area with danger of explosive	Marking of exterior ambient	Classification of area	
		Marking	Complusory regulation
Danger of explosion of inflammable dust	BE3N1	ZONE 22	ČSN EN 60079-14 ČSN EN 60079-10-2
Danger of explosion of inflammable gas and vapors	BE3N2	ZONE 2	ČSN EN 60079-14 ČSN EN 60079-10-1

In case of any erving on light fitting in premises with danger of explosion, the national safety rules and regulation for prevention of accidents are to be observed. SALUKA-N-LED are LED dust proof and waterproof lighting fixtures designed for lightening premises with danger of explosions. SALUKA-N-LED-Em - non maintained emergency lifting. MULTISALUKA-N-LED - maintened emergency lifting.

Technical data:

Permitted range of operating temperatures for 220-240V, 50/60Hz

SALUKA-N-LED-2500/5000-218/236	-20°C to +60°C
SALUKA-N-LED-5000/7500-218/258	-20°C to +55°C
SALUKA-N-LED-10000-236	-20°C to +50°C
SALUKA-N-LED-12550-258	-20°C to +45°C
SALUKA-N-LED-16700-258	-20°C to +50°C
SALUKA-N-LED-20000-258	-20°C to +45°C
MULTISALUKA-N-LED-5000-236	0°C to +45°C
MULTISALUKA-N-LED-2500/7500-218/258	0°C to +40°C
MULTISALUKA-N-LED-12550/258	0°C to +40°C
MULTISALUKA-N-LED-10000/236	0°C to +35°C
SALUKA-N-LED-Em-500-218/236/258	0°C to +50°C

Nominal voltage and frequency:

for electronic ballast HELVAR:	220-240V, 0/50-60Hz
for electronic ballast TRIDONIC:	220-240V, 0/50/60Hz
for electronic ballast TCI:	220-240V, 0/50-60Hz
for emergency unit AWEX:	220-240V, 50/60Hz
for emergency unit TRIDONIC:	220-240V, 50/60Hz

Lighting fixture dimensions:

Typ	A(mm)	B (mm)	C (mm)
SALUKA-N-LED-218	705	192	90
SALUKA-N-LED-236	1305	192	90
SALUKA-N-LED-258	1605	192	90

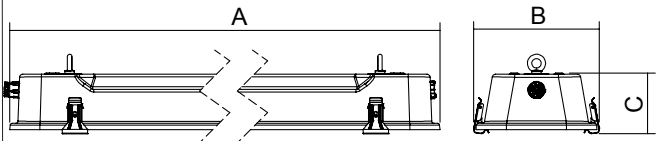

Maximum number of continuously connected luminaires for circuitbreaker type B10A

SALUKA-N-LED		
MULTISALUKA-N-LED		
SALUKA-N-LED-2500-218		23
SALUKA-N-LED-5000-218		23
SALUKA-N-LED-5000-236		23
SALUKA-N-LED-10000-236		18
SALUKA-N-LED-7500-258		18
SALUKA-N-LED-12550-258		18
SALUKA-N-LED-16700-258		9
SALUKA-N-LED-20000-258		

Pic. 1
Using the ceiling mounts

Pic. 2
Using to the tube caliper

Pic. 3
Direct attaching to the ceiling or wall

Pic. 4
Attaching by hanging eye

Operation and maintenance instructions:

The light fittings, which operate in areas of above mentioned premises, are under the requirements resulting from compulsory regulations of valid EN:

- The light fitting must not be open, if the terminal block is alive.
- Free outlets for supply cable must be sealed with plugs M20.
- Any change or replacements of components of the light fittings, which can influence the protection before the danger of explosion, are forbidden.
- The repair of the light fittings can be done only by person with relevant qualification, only with original spare parts and in compliance with the latest regulations.

The fixtures are certified by FTZÚ, AO 210, Ostrava – Radvanice:

- 1) Certificate of type FTZÚ 17 ATEX 0027X from date 10.05.2017
- 2) Supplement no.1 to certificate FTZÚ 17 ATEX 0027X date of issue 23. 03. 2022

Mountig:

1. Take the fixture from transporting packing
2. Remove metal clips fixed the glass, disconnect cable with carbine, remove the glass and take out bag with accessories.
3. Unbolt the screws M4x10 fixed reflector with housing and remove reflector..
4. The side opening in the body plant the cable gland (which is included in the luminaire equipment), and on the other side of her body screw the nut. Cable gland nut to the body, tighten torque 2,7Nm..
5. Fix the screws (see fitting). In order to ensure the required cover of the luminaire, the rubber seals must be used when mounting.
6. Pull the power cable through the cable gland. Tighten bushings to a state of partial deformation of the rubber sealing washers, tightening torque 2,5Nm. Supply cable must have an outer diameter in the range (see. Table sealing areas), which is a necessary condition for correct function of cable gland. Hole for power cable in the housing, which is not used cable gland (which is contained in the equipment luminaires), seal blanking plug. In the luminaire is not allowed to use respiratory protective plugs and cable glands breathing
7. Connect the suppling cable to the free part of incoming terminal strip as follows:

SALUKA-N-LED		SALUKA-N-LED-Em			
L	phase conductor	L1	cond. of charging phase	L1	cond. of charging phase
-	-	-	-	L2	cond. of switching phase
N	neutral conductor	N	neutral conductor	N	neutral conductor
⊕	protective conductor	⊕	protective conductor	⊕	protective conductor

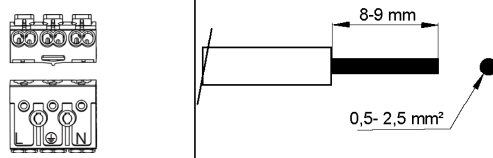

* To each pole of terminal block can be connected two conductors in cut 0, 75 - 2, 5 mm2. In case of through-wiring connection it is necessary to use accessories for such connection! In case that the label with the description of connection is glued on the reflector of luminaire, you must do connection according this description.

8. Tighten the screws M4x10 fixed reflector to the housing
9. Fix carbine with cable in outlet on the side of reflector and equip with glass cover.
10. Ensure enough sealing of glass cover with housing
11. Fix glass cover by means of metal clips. All clips secure the screws M4 lights, which can be found in the equipment lighting, screws tighten torque of 0,5Nm.

Test of operation:

For correct operation it is necessary to observe enclosed instruction about testing of emergency fixtures. Switch the luminaire off the mains voltage. The emergency LED module must light. The green LED in the reflector is off. Should the emergency lamp be extinguished within the test period though the battery is fully charged, the latter will have to be replaced by a new battery set.

Warning: The full battery capacity will be available after approximately three charging/discharging cycles.

Battery change:

"Replace the battery in a non-explosive environment"

Battery change is necessary when the fixture doesn't observe the conditions of rated operation period durability. In explosive area it is prohibited to disconnect battery for emergency unit. It is allowed to disconnect the fixture from supply voltage and take remove reflector from the fixture.

1. Disconnect the fixture from supply voltage.
2. Remove reflector from the housing.
3. Disconnect cable from terminal block.
4. Disconnect battery from emergency unit in non-explosive area as follows „-“black conductor and „+“red conductor.
5. Unbolt the nut of battery holder
6. Remove the old battery.
7. Screw the new battery (mark the date of operation start).
8. Connect conductors to battery as follows „+“red conductor and „-“black conductor.
9. Connect the fixture to supply voltage.
10. Equip with reflector and cover. Fix it with the clips.

WARNING: The battery in the fixture can be changed for the same type with same parameters only!!!

Table: List of cable glands:

Cable glands	Diameter of the cable for cable glands M25x1,5
OBO V-TEC Ex	∅ 7 mm - 12 mm
CEAG CHG 960 92.. P...	∅ 5,5 mm - 13 mm
WISKA ESKE/1 (S)(-L)(+)(-RDE)	∅ 7 mm - 13 mm
ELFIT UNI	∅ 7 mm - 12 mm
BIMED LYRA (EURO-TOP)	∅ 7 mm - 12 mm

Sealing of mounting holes:

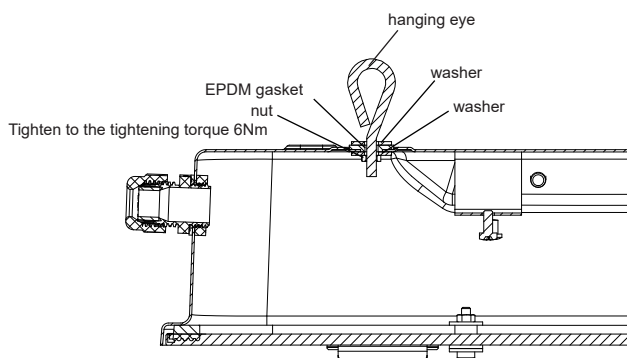

In case of any interventions on fixture lighting in premises with danger of explosion, the national safety rules and regulation for prevention of accidents are to be observed. Luminaires SALUKA-N-LED are LED dust proof and waterproof lighting fixtures designed for lightening premises with danger of explosions.



The light source and gasket in this lighting fixture can be replaced only producer or its contractual service technique or a similarly qualified person. When installing lighting fixture, observe the ESD safety using appropriate tools!

When the mounting instructions are not observed, the producer can't be responsible for incidental damages incurred.

The light source and gasket in this lighting fixture can be replaced only producer or its contractual service technique or a similarly qualified person. Any modification or replacement of components on the luminaire that affects the protection against dangerous explosions is prohibited. Repairs to luminaires may only be carried out by a suitably qualified person and only with original spare parts.



ATTENTION!!!

For wall installation of lighting fixture must be LED driver positioned facing downwards

WARNING – potential danger of electrostatic charging.

WARNING – the lighting fixture must be installed in the position, which does not allow the touch of persons and parts of the fixture.

WARNING – the lighting for fixed installation.

WARNING – the fixture should be cleaned with damp duster only. It is necessary to keep periodic cleaning intervals of lighting fixture

WARNING – do not open under voltage.

WARNING – replace protective cover



Producer included in recycling system provided by EKO-KOM Company (EK-F06070058).

INSTALLATION INSTRUCTIONS

