

Terminal box GHG 791 02



1 Technical data

Terminal box GHG 791 01/GHG 721 02

Marking acc. to 94/9/EC and directive:	Ex II 2 G Ex e d m ia IIC T6
EC type examination certificate:	Ex II 2 D Ex tD A21 IP 66 T80 °C
Rated voltage:	PTB 00 ATEX 3108 up to 690 V
Rated current:	acc. to table an the inside of the enclosure cover
Perm. ambient temperature:	-20° C up to +40° C (catalogue version)
Special versions permit deviating temperature ranges.	
Perm. storage temperature in original packing:	-40° C up to +80° C
Schutzart nach EN/IEC 60529:	IP 66 (catalogue version)
Insulation class acc. to EN/IEC 61140:	I - is complied with by the terminal boxes II - with internal earth plate
Supply terminal:	acc. to customers specification and as certificate
GHG 791 01	max. 4mm ²
GHG 791 02	max. 6mm ²
Cable entries:	acc. to customers specification and as certificate
Test torques:	
Cover screws	1.20 Nm
Cap nut of the M12 entry	1.65 Nm
Cap nut of the M16 entry	2.50 Nm
Cap nut of the M20 entry	2.50 Nm
Cap nut of the M25 entry	3.50 Nm
Cap nut of the M32 entry	5.00 Nm
Weight GHG 791 01:	
empty weight	approx. 0.25 kg
with internal earth plate	approx. 0.30 kg
Weight GHG 791 02:	
empty weight	approx. 0.45 kg
with internal earth plate	approx. 0.52 kg
Intrinsically safe circuits:	
Max. safe voltage U _m	690 V _{eff} Safe galvanic isolation from all other circuits and earth

Dimensions in mm

X = fixing dimensions

Terminal box GHG 791 01

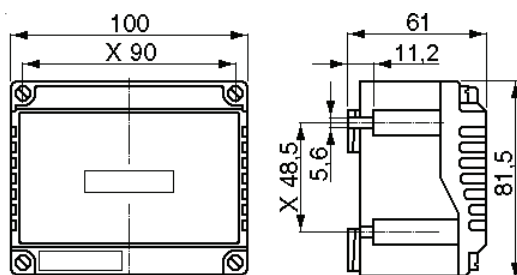

Terminal box GHG 791 02

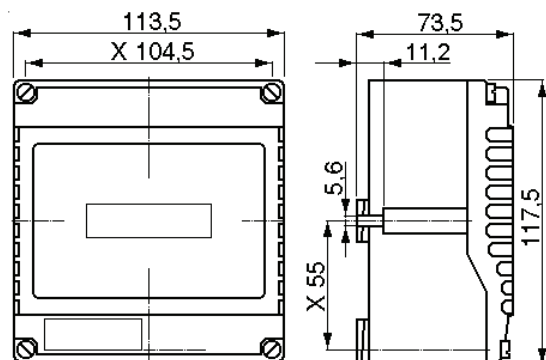

Explosion protected terminal boxes GHG 791 01 and GHG 791 02

Terminal box GHG 791 01



2 Safety instructions

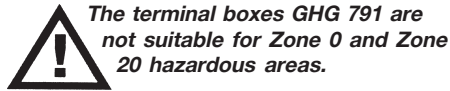

The operations must be carried out by electrical suitably trained in hazardous area with knowledge of increased safety explosion protection.

The temperature class and explosion group marked on the terminal boxes shall be observed.

The requirements of the EN 61241-0 and -1 regarding excessive dust deposits and temperature to be considered from the user.

Modifications to the terminal boxes or changes of their design are not permitted.

They shall be used for their intended purpose and in perfect and clean condition.

For replacement and repair only genuine COOPER CROUSE-HINDS spare parts shall be used. Repairs that affect the explosion protection, may only be carried out by COOPER CROUSE-HINDS or a qualified electrician in compliance with the respective national regulations.

Prior to taking the terminal boxes into operation, they shall be checked in accordance with the instruction as per section 6.

Before the initial operation, any foreign matter shall be removed from the terminal boxes.

Observe the national safety rules and regulations for prevention of accidents as well as the safety instructions included in these operating instructions and set in italics the same as this text!

3 Conformity with standards

The apparatus is conform to the standards specified in the EC-Declaration of conformity, enclosed separately.

It has been designed, manufactured and tested according to the state of the art and to DIN EN ISO 9001.

94/9 EC: Equipment and protective systems intended for use in potentially explosive atmospheres.

The apparatus fulfil further requirements, such as the EC directive on electromagnetic compatibility (2004/108/EEC).

4 Field of application

The terminal boxes GHG 791 01 and GHG 791 02 are suitable for use in Zone 1 and 2 as well as in Zones 21 and 22 hazardous areas acc. to IEC 60 079-10 and IEC 60 079-14!

The enclosure materials employed, including the exterior metal parts, are made of high-quality materials which ensure a corrosion protection and resistance to chemical substances corresponding to the requirements in a "normal industrial atmosphere":

- impact resistant polyamide
- special steel AISI 316 L

In case of use in an extremely aggressive atmosphere, please refer to manufacturer.

5 Use/Properties

The terminal boxes are intended for the distribution of electrical energy e.g. light circuits, heater circuits, control circuits, intrinsically safe circuits etc. in hazardous areas (see technical data). The temperature class, explosion group and permissible ambient temperature, see technical data.

The electrical limiting values that are decisive for the intrinsic safety shall be observed.

The terminal boxes can also be used in a „normal industrial area“.

The data as per point 3 and 4 shall be taken into account with the use.

Applications other than described are not permitted without COOPER CROUSE-HINDS's prior written consent.

For the operation, the instructions stated in section 7 of the operating instructions shall be observed.

The user alone is responsible for the appropriate use of this terminal box in consideration of the basic conditions existing at the plant (see technical data).

6 Installation

For the mounting and operation, the respective national regulations (e. g. Betr.Si.V, equipment safety law for Germany) as well as the general rules of engineering shall be observed.

Fig. 1

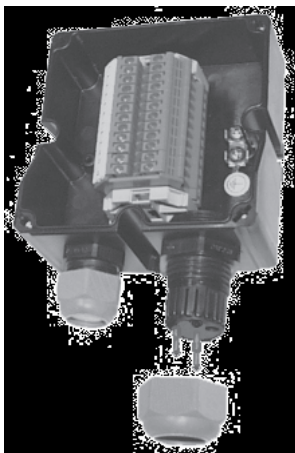

Explosion protected terminal boxes GHG 791 01 and GHG 791 02

Fig. 2

Size 1 apparatus holder for GHG 791 01

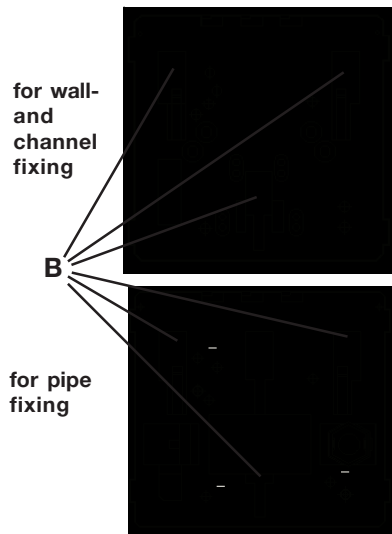

Size 2 apparatus holder for GHG 791 02

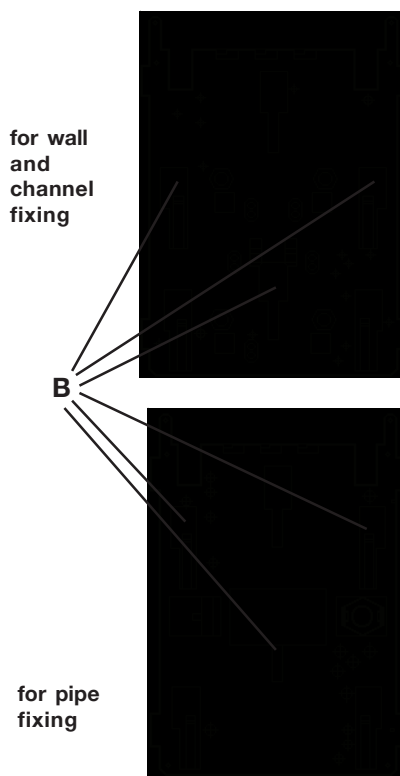

6.1 Mounting

The terminal boxes can be mounted without opening their enclosure.

In case the terminal boxes are mounted directly onto the wall, they may rest evenly only at the respective fastening points. The chosen screw shall match the fastening hole (see dimensional drawing) and it must not damage the hole (e. g. use of a washer). The device shall be fastened diagonally with at least 2 screws.

If the screws are overtightened, the apparatus can be damaged.

The terminal boxes are suitable for fixing onto COOPER CROUSE-HINDS apparatus holders size 1+ 2 by means of self-cutting screws (see fig. 2, fixing point "B").

The respective mounting instructions shall be observed.

6.2 Opening the device/ Electrical connection

Before opening the apparatus, it is necessary to ensure that there is no voltage or to take suitable protective measures.

The electrical connection of the device may only be carried out by skilled staff in acc. to 60 079-14.

The insulation of the conductors shall reach up to the terminal. The conductor itself shall not be damaged.

The properly bared conductors of the cables shall be connected, taking into account the respective regulations.

The connectible min. and max. conductor cross-sections will have to be observed (see technical data).

All screws and/or nuts of the supply terminals, also of those remaining unused, shall be tightened down.

The conductors shall be connected with special care in order to maintain the explosion category.

The supply terminals are designed for the connection of copper conductors. If multi- or fine-wire connecting cables are used, the wire ends will have to be handled in acc. with the applicable national and international rules (e. g. use of ferrules).

The table indicating the current load values which is provided on the cover inside of the terminal boxes is to be observed.

In case of mixed equipment Ex e / Ex-i, the required minimum distances will have to be kept (see e.g. EN 60079-11).

When apparatus is open, it is necessary to ensure (disconnect voltage supply) that no voltage is carried over into the connected intrinsically safe circuits.

The installation instructions for intrinsically safe electrical apparatus shall be observed. It is necessary to ensure that the permissible external capacitance and inductance of the special intrinsically safe circuits are not exceeded.

6.3 Cable entries (KLE); blanking plugs

Generally, only certified cable entries and blanking plugs may be used.

Flexible cables are to be used with trumpet-shaped cable glands or other suitable entries with additional pull-relief.

The mounting directives applicable to the fitted cable entries are to be observed.

When using cable entries with a lower IP protection than that which applies to the device (see technical data, page 9 + 10), the IP protection of the whole device will be reduced.

In order to establish the minimum protection category, unused holes have to be closed with a certified blanking plug.

Care has to be taken that when fitting the cable entries, sealing inserts appropriate to the cable diameter are used.

In case of sealing inserts that are cut out, it will have to be ensured that the insert is properly adapted to the cable diameter.

When using cable entries for fixed cables it is necessary to ensure that no inadmissible high mechanical stress is applied to the cable entry or its seal.

Intrinsically safe circuits shall be fed through cable entries that are colour-coded (light blue).

All vacant metric COOPER CROUSE-HINDS cable entries are to be closed with the certified blanking plug for metric cable entries (see page 8, fig. 1).

Explosion protected terminal boxes GHG 791 01 and GHG 791 02

In order to ensure the required minimum protection category, the cable glands shall be tightened down.

Overtightening might impair the protection category.

Attention: The metal frame and metal glands are to be integrated into the potential equalization.

6.5 Closing the device/ cover closure

Any foreign matter shall be removed from the apparatus.

In order to ensure the required minimum protection category, the cover screws are to be tightened down.

Overtightening might impair the protection category.

6.6 Taking into operation

Prior to taking the apparatus into operation, the tests specified in the relevant national regulations will have to be carried out.

Apart from that, the correct functioning and installation of the apparatus in accordance with these operating instructions and other applicable regulations will have to be checked.

Incorrect installation and use of the terminal boxes can invalidate the guarantee.

7 Maintenance/ Servicing

The relevant national regulations which apply to the maintenance/servicing of electrical apparatus in explosive atmospheres, shall be observed (EN 60079-17).

Before opening the enclosure make sure that the apparatus is disconnected from the voltage, or take the appropriate protective measures.

In case of intrinsically safe circuits, working is permitted while voltage applies.

The required maintenance intervals depend on the respective application and will therefore have to be determined by the user dependent on the conditions of use.

Cleaning:

 Because of the risk of an electrostatic charge, the junction boxes shall only be cleaned with a damp, non fibrous cloth or sponge!

When servicing the apparatus, particularly those parts that are decisive for the type of protection against explosion, will have to be checked (e. g. intactness of enclosure, cable glands, efficacy of the cover gaskets).

If during servicing repairs prove to be necessary, section 8 of these operating instructions will have to be observed.

8 Repairs / Overhaul / Modification

Repairs may only be carried out with genuine COOPER CROUSE-HINDS spare parts.

Repairs that affect the explosion protection, may only be carried out by COOPER CROUSE-HINDS or a qualified electrician in compliance with the applicable national rules (EN 60079-19).

Modifications to the apparatus or changes of its design are not permitted, except for the mounting of additional cable entries and the installation of supply terminals in accordance with the approval of the apparatus.

9 Disposal / Recycling

When the apparatus is disposed of, the respective national regulations on waste disposal will have to be observed.

In order to facilitate the recycling of individual components, plastic parts have been provided with the identification mark of the plastic material used.

Subject to modifications or supplement of the product range.