



EEx II Strobe Light dSLB 20

**Robust optical signalling device
for use in areas with
explosive atmospheres
in group II and zones 1 + 2**

- ▶ Compact construction
- ▶ Versatile
- ▶ Light intensity to 15 joule
- ▶ Protection degree IP 67
- ▶ Explosion protection class II 2G EEx de IIC T6

Application

It is often necessary to use optical signals for warning, indicating and signalling purposes in areas with explosive atmospheres.

The EEx II strobe light dSLB 20 offers these signalling possibilities. It is designed for continuous operation. The dSLB 20 strobe light is activated by switching on the power supply and is available with various rated voltages. The sturdy housing conforms to protection degree IP 67 and can be installed both indoors and outdoors.

Design

The EEx II strobe light consists of a small flameproof housing of aluminium containing the electronics and a glass cap of hardened borosilicate glass.

The terminal enclosure is realised in the explosion protection mode "increased safety".

Use on a forklift truck

The sturdy housing conforms to protection degree IP 67 and can be installed both indoors and outdoors.



Technical specifications

Housing	Aluminium, surface lacquered or powder-coated
Colour	Yellow/Blue with hardened glass cap and protective cage of stainless steel, 5 joule version without protective cage
Cap colours	Transparent, red, yellow, green, blue
Protection degree	IP 67 (IEC 529)
Protection class	I
Cable gland	15 joule-variant = 1 x M 20 x 1.5 and 1 x blind plug M 20 x 1.5 5 joule-variant = 1 x M 20 x 1.5 on the side
Connection terminals	Power supply: Cross section – 2.5 mm ² single wire 1.5 mm ² fine wire Protective earth – Screw connection with wire protection clamp in connection enclosure max. 2.5 mm ² Equipotential – Screw connection with wire bonding conductor protection clamp outside, cross section max. 4 mm ²
Operating conditions	Indoors and outdoors
Operating position	Any
Operating mode	Continuous
Flash energy	5 joule / 15 joule
Flash frequency	Approx. 60/min. (1 Hz)
Average lifetime	Approx. 5 x 10 ⁶ flashes
Temperature range	
Operation	-20° C to +40° C
Storage	-25° C to +70° C
Expl. protection class	II 2G EEx de IIC T6
Approval	PTB 99 ATEX 1028
Weight	Approx. 2 kg

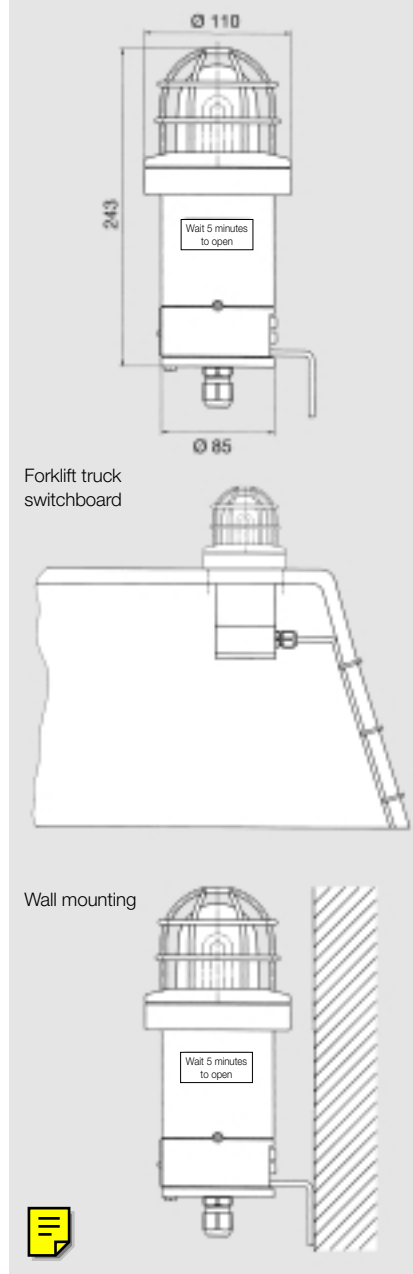

Order information

* The full article number is made up by appending the colour code for the coloured cap to the article numbers given below.

transp.	01
red	02
yellow	03
green	04
blue	05

Type	Name	Rated voltage	Flash energy	Current consumption	Art. no.*
dSLB 20	EEx II Strobe Light	24 VDC (21–53 VDC)	15 Ws	1 A	224 963 ..
dSLB 20	EEx II Strobe Light	80 VDC (72–132 VDC)	15 Ws	250 mA	224 965 ..
dSLB 20	EEx II Strobe Light	230 VAC (207–253 VAC)	15 Ws	200 mA	224 997 ..
dSLB 20	EEx II Strobe Light	12 VDC	5 Ws	in preparation	224 912 ..
dSLB 20	EEx II Strobe Light	24 VDC (21–53 VDC)	5 Ws	280 mA	224 913 ..
dSLB 20	EEx II Strobe Light	80 VDC (72–132 VDC)	5 Ws	90 mA	224 915 ..
dSLB 20	EEx II Strobe Light	115 VDC (103–127 VAC)	5 Ws	135 mA	224 906 ..
dSLB 20	EEx II Strobe Light	230 VAC (207–253 VAC)	5 Ws	130 mA	224 907 ..

